

System	H15 (Head) + RT30B (Tripod) + SP-2B (Floor spreader) + RC-30 (Carrying case)		
Payload	3 kg / 6.6 lb	Tilt angle	+90° / -70°
Weight	6.2 kg / 13.6 lb	Pan angle	360°
Height	① H : 1662 mm W : 710 mm (※Reference)	Counterbalance	Range : 0.8 ~ 2 kg / 1.7 ~ 4.4 lb (C.G. 55 mm)
	② H : 562 mm W : 1105 mm (")		Perfect Balance
Folded length	③ L : 857 mm (")		Continuous Counterbalance with Illuminated Meter
Camera plate (Sliding range)	Sliding plate (compatible with Manfrotto and Sachtler)	Drag mode	Free plus 3 steps
	One touch attach and release mechanism	Drag system	Multilayered Metal Structure
Plate attachment (Screw sliding range)	1/4-20UNC (with video boss)	Temperature range	-40 °C ~ +60 °C / -40°F ~ +140°F
Spare screw	1/4-20UNC × 1 , 3/8-16UNC × 1	Head base	Ball 75 mm / Flat base with 3/8" female thread
	Equipped on the top of the head (beneath sliding plate)	Accessory port	Screw hole 1/4" × 1 , 3/8" × 1
Bubble level	Illuminated	Section	2-Stage
		Tripod fixation	Fixing lock knob
		Spreader	SP-2B (Telescopic , Removable)
		Pan handle	PH-6B (Telescopic)
		Case material	Nylon , Polyester , TPE , PE , PP , POM

Remarks

■ Exterior Dimensions (mm)

■ Sliding plate

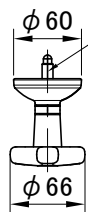
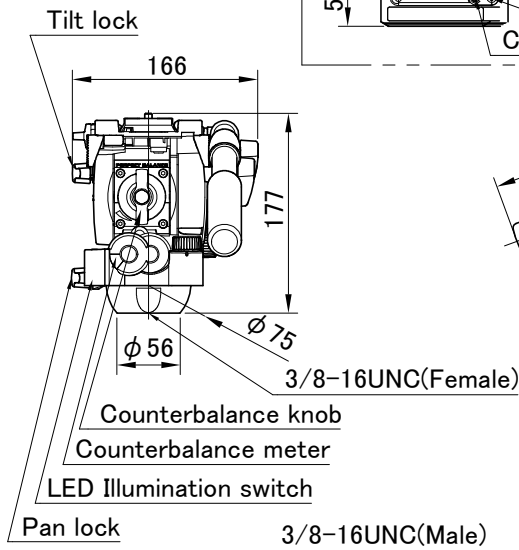
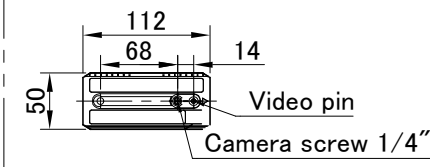

※ Reference

